

Technical Data Information

Saldo Chrome Bath Shower Mixer
AVHD04

R.T. LARGE

ESTABLISHED 1969

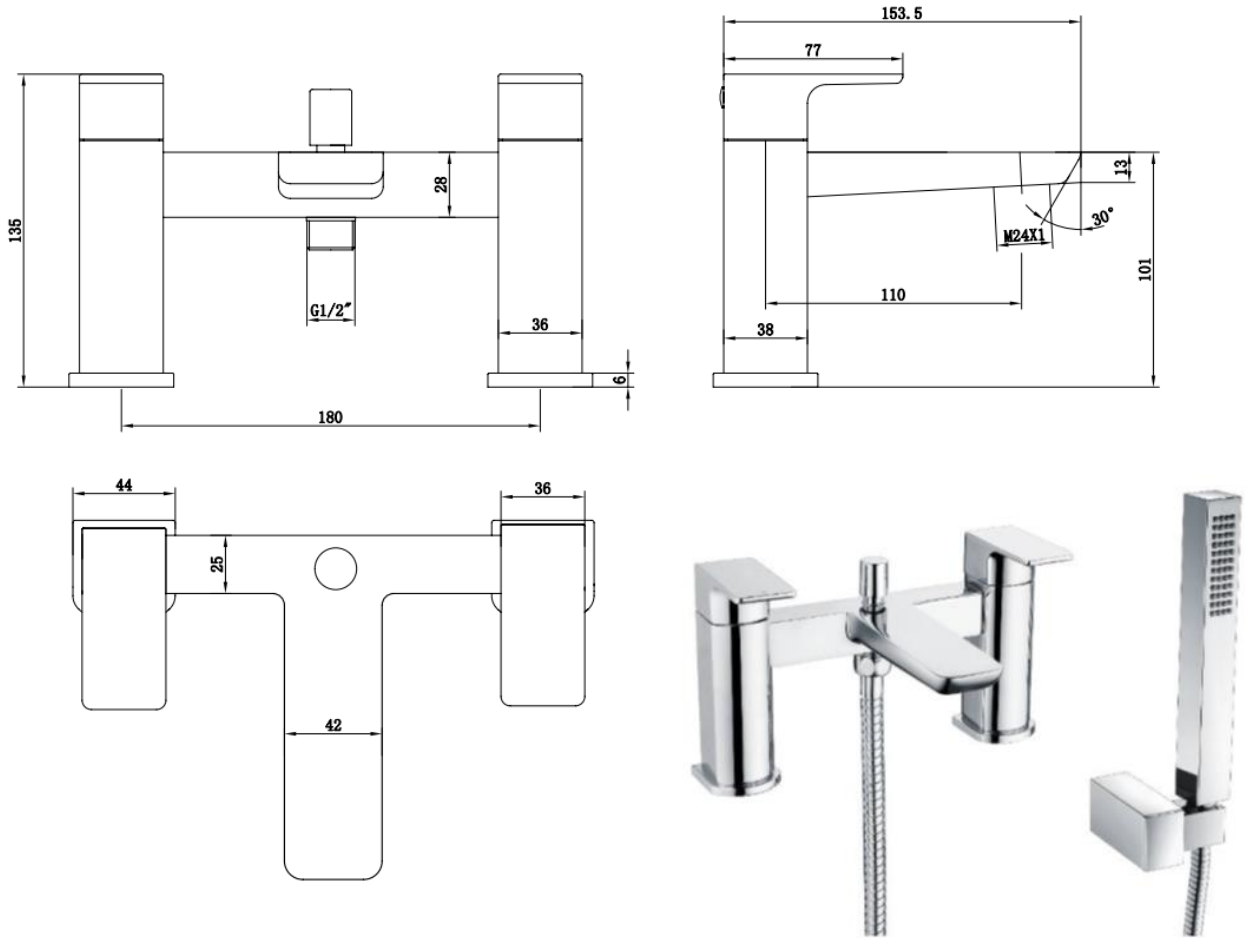

INFORMATION

Construction	Brass Body CuZn40Pb2, EN CW617N (equivalent to BS CZ122)
Finishes	Chrome plated to BS EN 248
Product Type	Contemporary
Water Pressure	Min. 0.2 bar, Max. 6.0 bar
Plumbing Systems	Suitable for all plumbing systems
Standards	Complies with BS5412, BS EN200
Certification	Manufactured to comply with WRAS
Cartridge	1/4 Turn 3/4" Ceramic Disc Valves
Fitting	3/4" BSP tails
Aerator	Neoperl aerator
Packaging	49 x 28 x 34.5cm / carton (4 boxes / carton); Box size: 24.5x21.5x15.5cm; Weight: 3.5kg/box
Guarantee	10 years against manufacturing faults (excluding serviceable parts).
Additional Information	Supplied with PVC 1.5m hose, wall bracket and single mode chrome ABS handset

All Dimensions are in millimetres. The information contained on this page was correct at date of issue. Fitting dimensions are provided as a guide only. Some variation may occur due to manufacturing tolerances. We pursue a policy of continuing improvement in design and performance of our products and so reserve the right to change specifications without prior notice.

R.T. LARGE

ESTABLISHED 1969

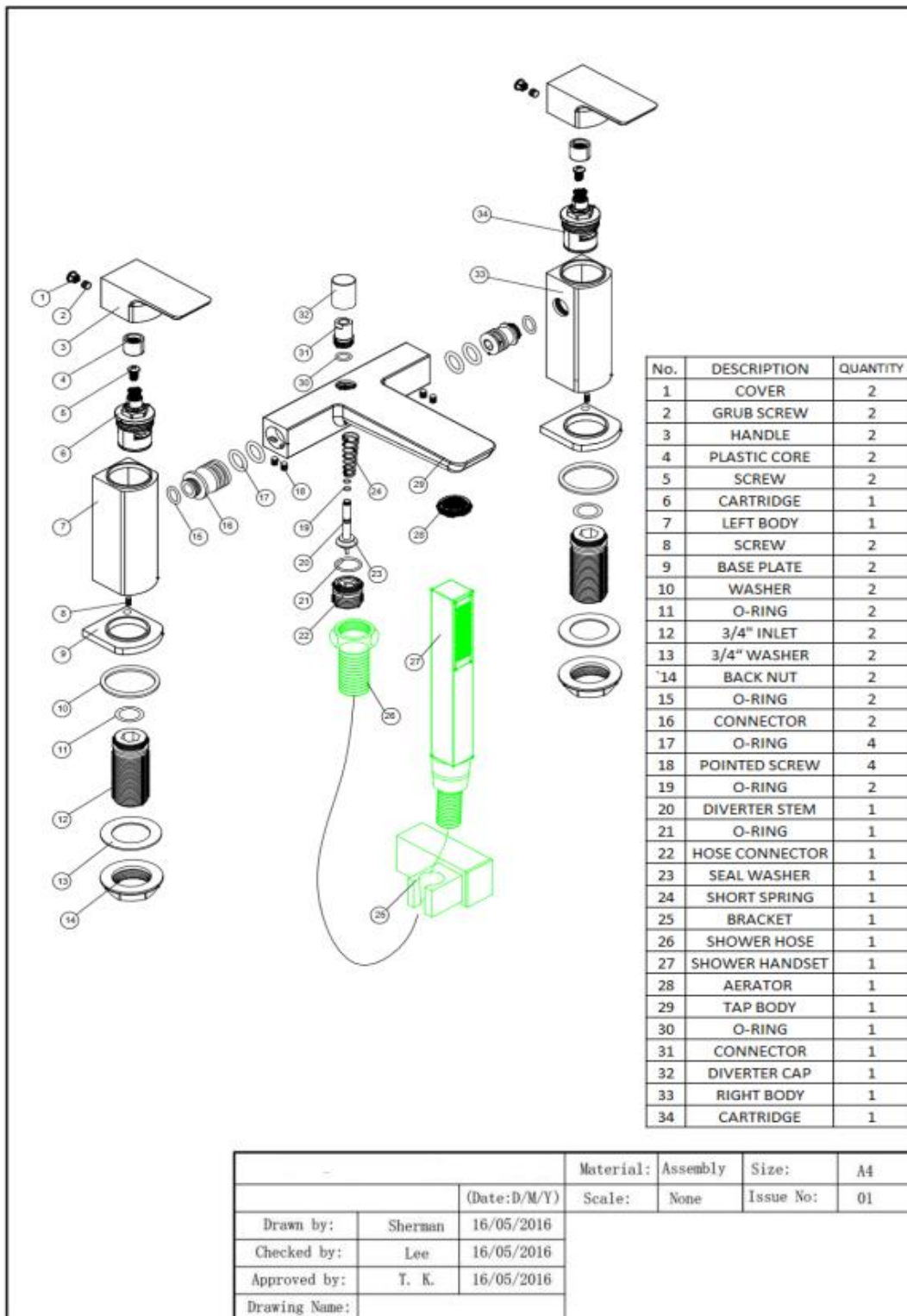

Flow Rates (Litres per minute)

System Pressure	0.1 Bar	0.2 Bar	0.3 Bar	0.5 Bar	1.0 Bar	1.5 Bar	2.0 Bar	3.0 Bar	4.0 Bar	5.0 Bar
HD04	7.5	10.8	-	16.5	23.5	28.2	32.6	39.5	-	-

All Dimensions are in millimetres. The information contained on this page was correct at date of issue. Fitting dimensions are provided as a guide only. Some variation may occur due to manufacturing tolerances. We pursue a policy of continuing improvement in design and performance of our products and so reserve the right to change specifications without prior notice.