

Technical Data Information

Product Code: MON60WHXXX

Information: **Monta 600mm Wall Hung**
Available in Dusty Pink, Cacao Brown & Cashmere Grey

Unit Dimensions: **H: 560mm x W: 590mm x D: 460mm**

Features:

- Units come with glass drawers
- Lower drawer with glass sides
- Anti slip mats included
- Camar hangers
- Chamfered fronts.
- Units fully produced from MDF painted from both sides
- High transverse tensile strength and edge stability
- Resistant to wear, impact and scratches.

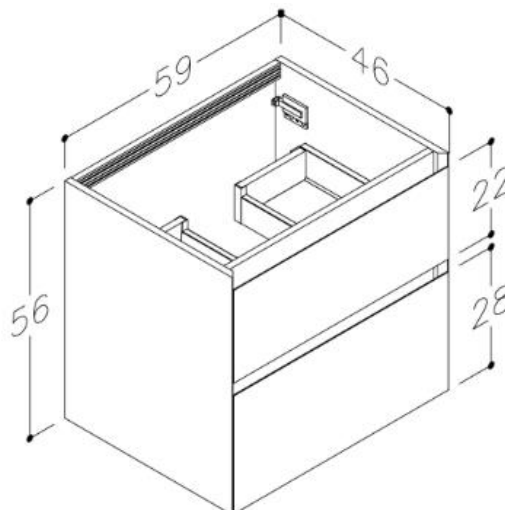

All Dimensions are in millimetres. The information contained on this page was correct at date of issue. Fitting dimensions are provided as a guide only. Some variation may occur due to manufacturing tolerances. We pursue a policy of continuing improvement in design and performance of our products and so reserve the right to change specifications without prior notice.